

PART NO.	ENG. NO.
02-06-1101	1561-(P901)
02-06-1103	1561-(P901)L
02-06-5101	1561-(P561)
02-06-5102	1561-(P561)L
02-06-5108	1561-(P228)
02-06-5109	1561-(P228)L
02-06-5100	1561-(P550)
02-06-5103	1561-(P550)L
02-06-5105	1561-(P591)
02-06-5104	1561-(P591)L
02-06-1118	1561-1(P901)
NOT TOOLED	1561-1(P901)L

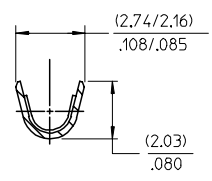

SECT. "B-B"  
SCALE:10X

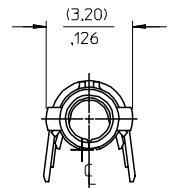
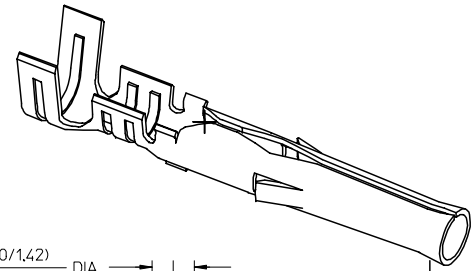
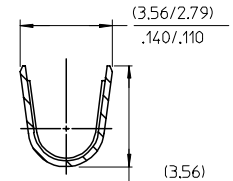

SECT. "C-C"  
SCALE:10X

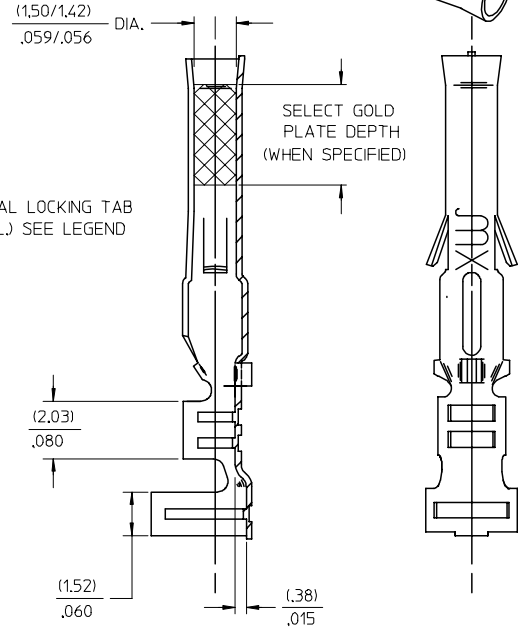
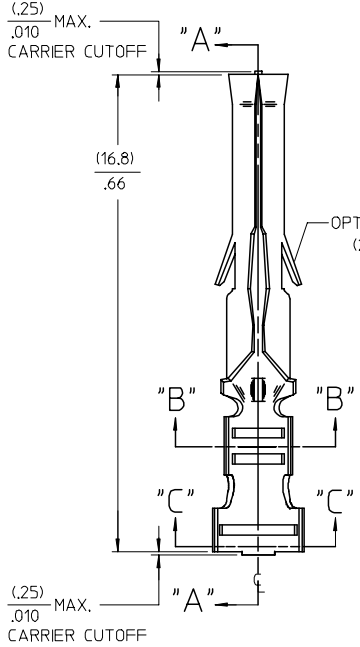

SECT. "A-A"

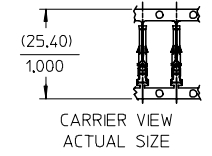

LEGEND

1561-\*(\*\*\*\*)\*  
 BLANK=WITH LOCKING TABS  
 1=WITHOUT LOCKING TABS  
 P=PREPLATE  
 BLANK=POSTPLATE  
 FORM  
 BLANK=CHAIN  
 L=LOOSE  
 FINISH CODE

- NOTES:
- MATERIAL: BRASS
  - FINISH:
    - 901 HOT TIN DIP (.00051)/.000020 MIN.
    - 228 SELECT GOLD PLATE (.00075)/.000030 MIN. IN CONTACT AREA, SELECT TIN, (.00250)/.000100 MIN. IN CRIMP AREA OVER (.00125)/.000050 MIN. NICKEL OVERALL.
    - 561 SELECT GOLD PLATE (.00076)/.000030 MIN. IN CONTACT AREA, OVER (.00127)/.000050 MIN. NICKEL OVERALL.
    - 591 SELECT GOLD PLATE (.00175)/.000050 MIN. IN CONTACT AREA, OVER (.00127)/.000050 MIN. NICKEL OVERALL WITH (.000025)/.000010 MAX. GOLD FLASH OVERALL.
    - 550 SELECT GOLD PLATE (.00038)/.000015 MIN. IN CONTACT AREA, OVER (.00076)/.000030 MIN. NICKEL OVERALL WITH (.000025)/.000010 MAX. GOLD FLASH OVERALL.
  - THE PRIMARY SHIPPING CARTON WILL BE LABELED, "COMPLIANT TO ROHS DIRECTIVE 2004/95/EC AND ANNEX II OF DIRECTIVE 2000/53/EC", AND CARTONS WITHOUT THIS LABEL MAY CONTAIN PRODUCT WITH TIN-LEAD."
  - PRODUCT SPECIFICATION: PS-02-06.
  - PACKAGING INFORMATION: NOT AVAILABLE
  - TERMINAL FOR USE WITH (1.57)/.062 DIA. SERIES HOUSINGS AND WILL ACCEPT 18 THRU 24 AWG WIRE WITH (1.52/3.05)/.060/.120 INSULATION DIA.

AP	REVISED/REDRAWN UCP2004-2257 RHOLTS 05/14/04
A0	REINSTATE 02065105 UCP2003-1827 ELHAG, 03/02/24
AN	OBSOLETE P/N UCR2002-0270 COMERCI 01/9/25
AM1	ADDED ISO VIEW UCR1998-0248 WANG 98-05-21
AM	REV. AND REDRAWN PER ECR 10372 GEP 8-20-87 RW

SEE REVISION BLOCK EC NO: UCP2004-2257 DRW:RHOLTS 2005/03/03 CHKD:FSMITH 2005/03/30 APPR:FSMITH 2005/04/11	QUALITY SYMBOLS	GENERAL TOLERANCES (UNLESS SPECIFIED)	SCALE 6:1	DESIGN UNITS INCH	THIRD ANGLE PROJECTION	REVISE ON CAD ONLY
	DESCRIPTION AP	4 PLACES ± --- ± --- 3 PLACES ± --- ± .005 2 PLACES ± 0.13 ± .010 1 PLACE ± 0.25 ± --- ANGULAR ±1/2°	DIMENSION STYLE IN/MM		TITLE	
			DRAWN BY GEW DATE 1991/02/19		CRIMP TERMINAL, FEMALE .062 DIA. FOR 18-24 AWG WIRE	
			CHECKED BY RW DATE 1991/02/19		MOLEX MOLEX INCORPORATED	
DRAFT WHERE APPLICABLE MUST REMAIN WITHIN DIMENSIONS		APPROVED BY GWF DATE 1991/02/19	MATERIAL NO. SEE CHART	DOCUMENT NO. SD-1561-*	SHEET NO. 1 OF 1	